

Installation Instructions for HIGH-PRESSURE COMPRESSORS Models 800-C and 840-C

Your purchase of a WOLO high-pressure compressor is a perfect choice to power your high-pressure air horns, tools and accessories. The Wolo name, with more than thirty years of experience, is your guarantee of a superior product. If you need help installing this product, our technicians are available to answer your questions, Monday through Friday from 9 AM to 4 PM EST by calling 1-888-550-HORN (4676).

COMPRESSOR INSTALLATION (Fig. 1):

1. Locate a convenient location to mount the compressor that will be dry. If the location is the engine compartment make sure the compressor is safe from the heat of the exhaust manifold and try to mount compressor as far to the front of vehicle as possible to provide optimum airflow around compressor. **IMPORTANT!** Do not mount on a plastic fender well, or on flexible material.
2. Using the compressor's mounting base as a template, mark the hole locations and drill to size, use a 3/16" drill bit. Secure the compressor to the mounting surface using the hardware provided.

Fig. 1

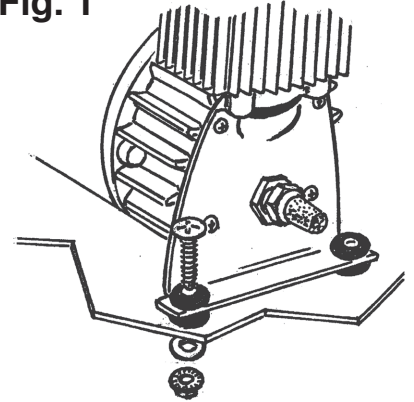

HOSE INSTALLATION (Fig. 2):

3. Connect the compressors stainless steel braided hose to tanks inlet port. **IMPORTANT:** Make sure the tanks inlet port is 1/4" N.P.T. (National Pipe Thread). The threaded fitting at the end of the braided hose has been wrapped with Teflon® tape to prevent air leaks, do not remove the tape.

Fig. 2

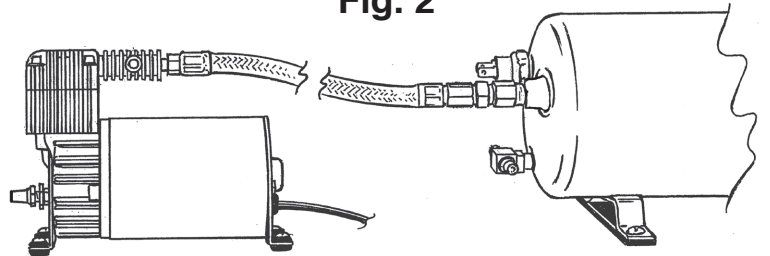

WIRING COMPRESSOR (Fig. 3):

4. The compressor's red wire is connected to a (+) 12-volt power source, using the 25-amp inline fuse provided. **IMPORTANT:** The red fused wire must be connected to a (+) 12-volt power source that is controlled by the vehicle's ignition switch. This will protect your compressor from being damage if an air leak develops when the vehicle is not in operation. Suggested electrical connection points are: blower motor, windshield wiper motor or the accessory terminal on the fuse panel. Make sure the connection point has a wire that is as heavy as the compressor's wires and the connection point is capable of handling 25-amps. **CAUTION:** remove the fuse from the fuse holder until installation is complete. **OPTIONAL:** A switch can be installed into the compressor's red wire. This will permit the driver to turn-off the system if it is not required.
5. The rubber boot with the two black wires will connect to the pressure switch. **IMPORTANT:** It is recommended that both black wires be pushed forward into the plug so that 1/4" female terminals are exposed.
6. The 1/4" female terminal connected to one of the black wires, is connected to a male terminal of the pressure switch. Repeat the procedure for the other for the other black wire. **NOTE:** There is no polarity, so either black wire can be connected to either pressure switch terminal.
7. Push the rubber boot onto the pressure switch.
8. The black wire with the loop terminal is connected to ground; secure the wire's terminal to either the (-) side of vehicles battery or under any metal body bolt. Make sure that ground connection is free of rust and paint.

Fig. 3

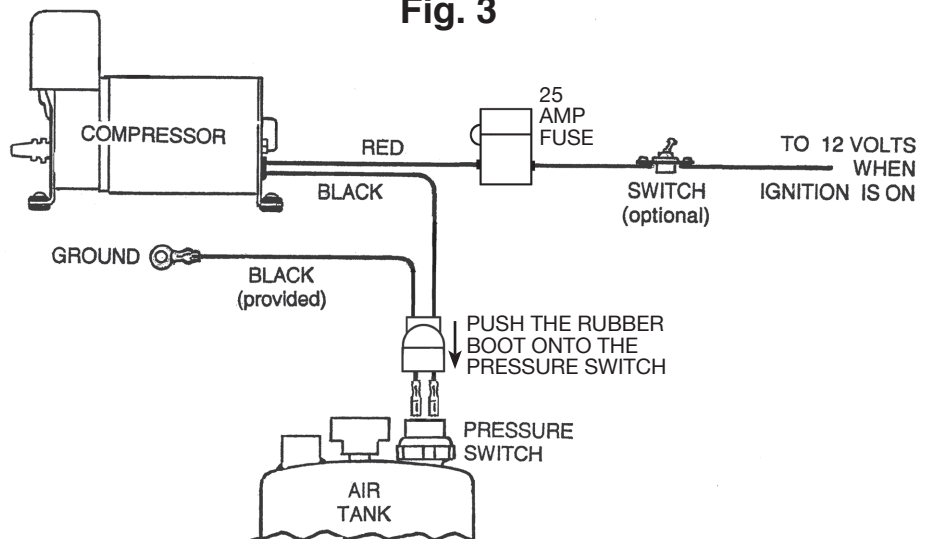

9. The compressor is now ready to be used. Install the fuse back into the fuse holder and the compressor will automatically start.

Depending on the pressure switch's on/off specification, when the pressure in the tanks drops below 80 PSI in the tank, the pressure switch will automatically turn on the compressor. When the tank pressure is approximately 120 PSI the compressor will automatically turn off. If the compressor does not shut off after 4 minutes of running time, check all air hose connections for air leaks. Use soapy water or bubble solution on each fitting, while the compressor is pumping. If leak persists after tightening, remove fitting clean and apply Teflon tape or thread sealant and reinstall fitting.

CAUTION: Do not touch compressor or fittings with bare hands during or immediately after usage, they will be hot.

IMPORTANT: Compressor is equipped with an internal THERMAL OVERLOAD PROTECTOR. If compressor should shut off before the tank has been filled to the pressure switch's turn off pressure, do not attempt to restart compressor. Allow compressor to cool off for approximately 40 minutes before resuming use.

The compressor comes from the factory permanently lubricated and the motor is maintenance free. Never attempt to lubricate, modify or service the compressor. Any required repairs should only be done by Wolo Manufacturing Corp.

MODEL 800 COMPRESSOR SPECIFICATIONS:

12-Volt heavy-duty compressor
Current: 10 amps at peak
CFM: 1.38
In-line fuse holder with 25 amp fuse provided
Permanent magnetic motor that is gearless and thermally protected
Oil-less maintenance free design
High performance piston ring
Moisture & dust resistant
Painted aluminum alloy cylinder
Mounting base has rubber vibration bushings
Stainless steel braided hose with in-line check valve
Built-in air filter

MODEL 840 COMPRESSOR SPECIFICATIONS:

12-Volt heavy-duty compressor
Current: 12 amps at peak
CFM: 2.03
In-line fuse holder with 25 amp fuse provided
Permanent magnetic motor that is gearless and thermally protected
Oil-less maintenance free design
High performance piston ring
Moisture & dust resistant
Painted aluminum alloy cylinder
Mounting base has rubber vibration bushings
Stainless steel braided hose with in-line check valve
Built-in air filter

Warranty

Wolo Manufacturing Corporation ("Wolo") warranties to the original purchaser, for three months from the date of purchase, that this product is free from defects in workmanship and materials. If there is such a proven defect, Wolo, at its option, will either repair or replace the item free of charge, if it is returned to Wolo within three months from the date of purchase together with proof of purchase as described below. Wolo reserves the right to inspect any defect prior to settling any warranty claim by repair or replacement. This warranty is limited as above provided and Wolo will not be responsible for fire or other casualty or accident, due to neglect, abuse, abnormal use, modifications, faulty installation of this product, or natural causes.

ANY EXPRESSED WARRANTY NOT PROVIDED HEREIN IS EXCLUDED AND DISCLAIMED. THE IMPLIED WARRANTIES OF MERCHANTABILITY AND OF FITNESS FOR A PARTICULAR PURPOSE ARE EXPRESSLY LIMITED TO A TERM OF THREE (3) MONTHS. UNDER NO CIRCUMSTANCES SHALL WOLO BE LIABLE TO PURCHASER OR ANY OTHER PERSON FOR ANY SPECIAL OR CONSEQUENTIAL DAMAGES, WHETHER ARISING OUT OF BREACH OF WARRANTY OR OTHERWISE.

To obtain warranty service, return the product prepaid, and include the original bill of sale showing the date of purchase. Provide with the return a brief description of the problem. Also, include with the return a check or money order in the amount of \$20.00 to cover return shipping. Mail to:

Wolo Manufacturing Corp. One Saxwood Street, Deer Park, NY 11729
Attn: Warranty Service E-mail: tech@wolo-mfg.com